

Uruguay

The way towards to a digital society

Governance in digital health,
how we implement an EMPI

Pablo Orefice, MHA, Eng.

Fernando Portilla, Eng. Master in Medical Informatics

© Sebast732

equity

our **hallmark**



Population: 3,5 millions (half in capital)

Área: 176.215 Km², **capital** Montevideo, **dry border with Brazil:** 600km

PIB (PPA) per cápita, 2023: \$18.547 (BM)

Health expenditure, total. % of GDP: 8%. Per capita. (constant US\$): \$1,105

Mortality rate, <5 years, 2023: 6 per 1,000

Life expectancy: 2022: 78 years; women 81,69 years

Uruguay, a reference in transformation with equity

All **homes** with fiber optics

All **children** with a computer

All **retirees** with tablets.

All **citizens** with digital EHRs

All **citizens** with an electronic national ID.

All **people** with digital ID

All **agro-livestock** with electronic caravans

All government **services** online.

leader in

**TRANSPARENCY AND
OPEN GOVERNMENT**

leader in

CONNECTIVITY

leader in

DIGITAL RIGHTS

leader in

DIGITAL HEALTH

working together

member of

OPS



Organización
Panamericana
de la Salud



Organización
Mundial de la Salud
OFICINA REGIONAL PARA LAS
Américas

member of

—DN

DIGITAL NATIONS

member of

SNOMED
International

Leading healthcare
terminology worldwide

member of

GLOBAL DIGITAL HEALTH
PARTNERSHIP



Health reform

*more than **15** years of
progress*

***HEALTH
FINANCE** model
change*

***MANAGEMENT**
model change*

***HEALTH
DELIVERY**
model change*

*Medical Technology and Informatics infrastructure
SALUD.UY*



GOVERNANCE OF SALUD.UY INITIATIVE



Uruguay **Presidencia**

Ministerio
**de Economía
y Finanzas**

Ministerio
**de Salud
Pública**

<> **agesic**

-
- Define standards and rules for interoperability.
 - Implement pilot applications and proof of concept
 - Build and maintain core main interoperability infrastructure
 - Support providers in adopting initiatives
 - Change management

SALUD.UY TIMELINE

Continuos and sustained process

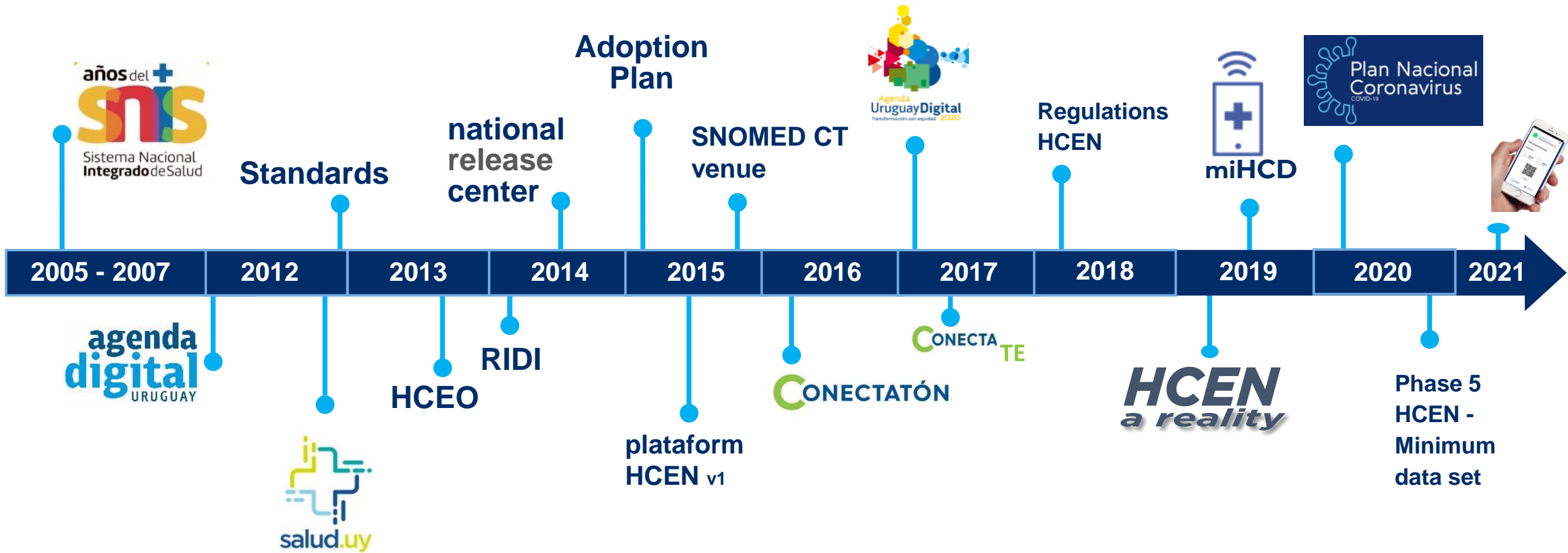

HCEN - SALUD.UY PLATFORM



Healthcare Providers
(public or private)



Healthcare Providers
(public or private)



Register people
create documents
store documents
register documents
consult documents





The Electronic Medical Record is a tool that is almost considered basic for healthcare organizations since it feeds information systems and, once again, helps in decision-making at all levels

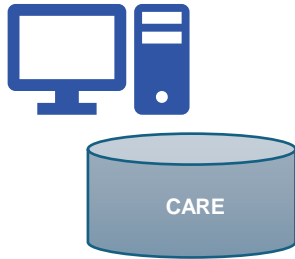

Hospital

Outpatient
Consultation

Imagery

Laboratory

Emergency
and Urgency

Special
Care

Surgical
Block

Pharmacies

ADOPTION PLAN

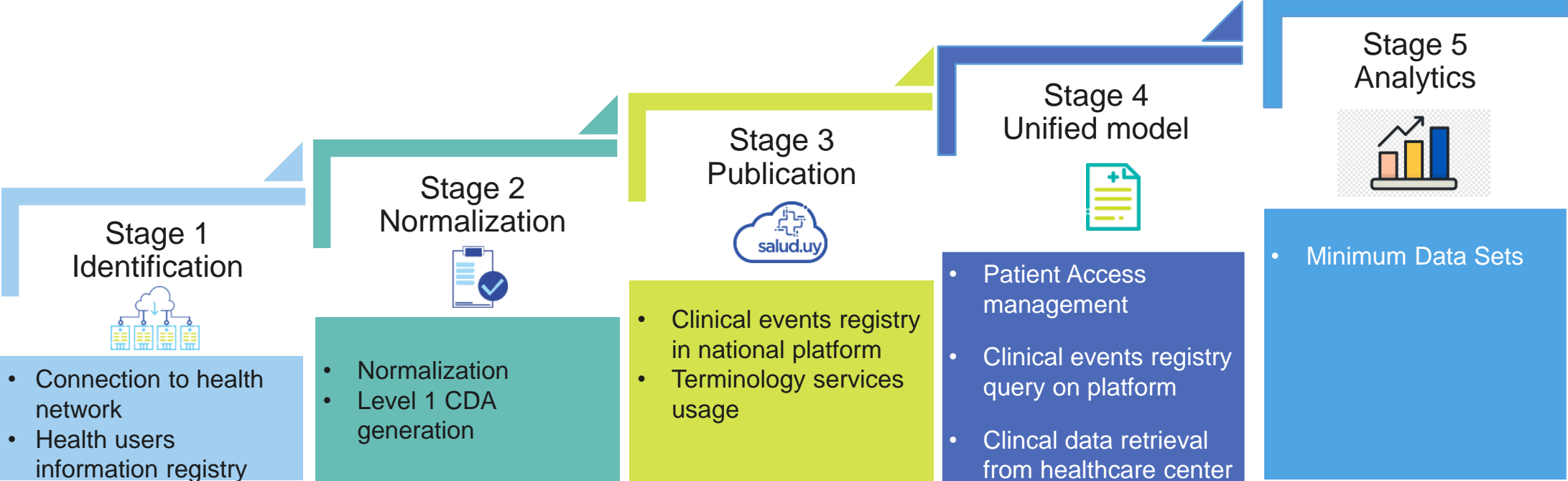

Cybersecurity

Change management

Adoption plan GOALS



% Health events registered in platform

Metas HCEN 2017 - 2020

% usuarios del sistema de salud con HCEN

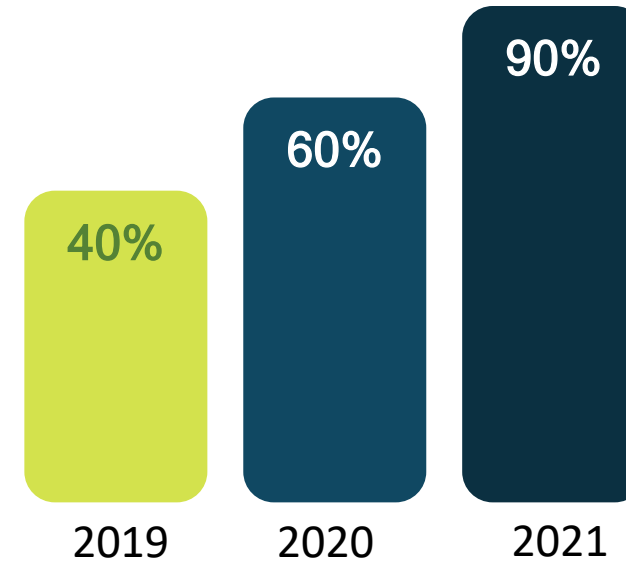

CONECTATÓN 2016



MY DIGITAL HEALTH RECORD

gub.uy Ingresá a Perfil gub.uy

salud.uy Historia Clínica Digital

Mi Historia Clínica Accesos y permisos Historial de accesos Mi salud digital

Historial de Accesos a mi Historia Clínica Digital a través de la plataforma HCEN

Mostrar: Todas las consultas Mis consultas Prestador 1 Prestador 2

| Fecha | Hora | Prestador SNIS | Observación |
|------------|-------|----------------------|-------------------|
| 06/11/2018 | 07:52 | Asociación Española | Consulta estándar |
| 23/10/2018 | 16:34 | Consulta del usuario | |
| 06/12/2018 | 07:52 | ASSE | Riesgo de vida |
| 06/12/2018 | 16:34 | Asociación Española | Consulta estándar |
| 06/12/2018 | 07:52 | ASSE | Riesgo de vida |
| 28/10/2018 | 16:34 | CASNU | Consulta estándar |
| 06/12/2018 | 07:52 | Consulta del usuario | |
| 06/12/2018 | 16:34 | Asociación Española | Consulta estándar |
| 06/12/2018 | 16:34 | Asociación Española | Consulta estándar |
| 06/12/2018 | 07:52 | ASSE | Riesgo de vida |
| 06/11/2018 | 07:52 | Asociación Española | Consulta estándar |

Filtros

Por categoría

- Policlínica (10)
- Urgencia y Emergencia (2)
- Internación (3)
- Imagenología (4)
- Laboratorio (8)
- Procedimientos (4)
- Otros (6)

Desde:

Hasta:

Aplicar filtros

Mi Historia Clínica Digital

Mostrando del 1 al 10 de 37 resultados

- 

22/05/2019
ASSE

Policlínica

 - Autor: **Juan Pérez**
 - Descripción: **Servicio de Medicina General**
- 

14/05/2019
ASSE

Urgencia y Emergencia

 - Autor: **Juan Pérez**
 - Descripción: **Emergencia Centralizada**
- 

17/04/2019
ASSE

Laboratorio

 - Autor: **Juan Pérez**
 - Descripción: **Laboratorio Central**
- 

08/04/2019
La Española

Internación

 - Autor: **Juan Pérez**
 - Descripción: **Servicio de cuidados moderados**

First case

03.13.2020

Proposal

03.15.2020

V1

03.20.2020

V2

03.30.2020

V3

04.30.2020

V4

06.15.2020

V5

10.15.2020

V6

12.19.2020

V7

03.15.2021



**+ 2,5 million
downloads**

09.30.2021

**+ 1,5 million
activations**

09.30.2021

1
Descarga la app



2 Úrsula y Mauro no se conocen, pero tienen una larga conversación sentados a poca distancia.

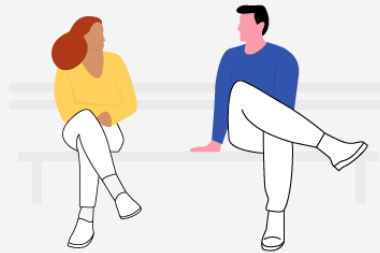

3 Sus teléfonos intercambian códigos anónimos generados al azar y que cambian frecuentemente.

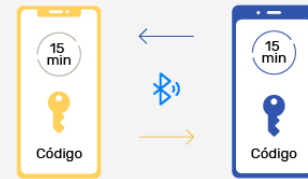

Algunos días después...



4 Mauro es diagnosticado positivo para COVID-19 y esto le es informado en la app Coronavirus UY.

5 Previo consentimiento de Mauro, su teléfono envía al servidor de Coronavirus UY los códigos anónimos que generó en los últimos 14 días.

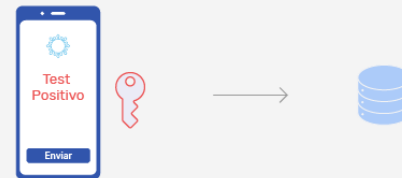

Los códigos sólo son enviados con el consentimiento del usuario

Almacenamiento temporal (14 días aprox.)



¿**HOW** ARE WE TODAY?



+195 millions

CLINICAL EVENTS COVERAGE

registred in the national platform
by healthcare providers



+95%



+82%

The HCEN: Summing up (National EHR)

- **This is NOT** an EHR software is a Health Platform
- The Health Platform provides the framework for a common need, in line with the country's health strategy
- It is **supported** on the electronic **government platform** (authentication, reliable, and security)
- It shall consist of the sum of the successive electronic clinical pages generated in the various patient care sites of the SNIS (Integrated National Health System)
- It shall initially contain indispensable information **to ensure the continuity of patient care**
- Each institution may have its own EHR system and **generate "sharable" clinical pages**
- Stakeholder inclusion and adoption plan, in a scalable manner and according to their technological maturity
- Based on international standards model but adjusted to the country's local reality

a new challenge:
being part of the

Pan-American Highway for Digital Health Initiative



Continuity of Care

Master Patient Index

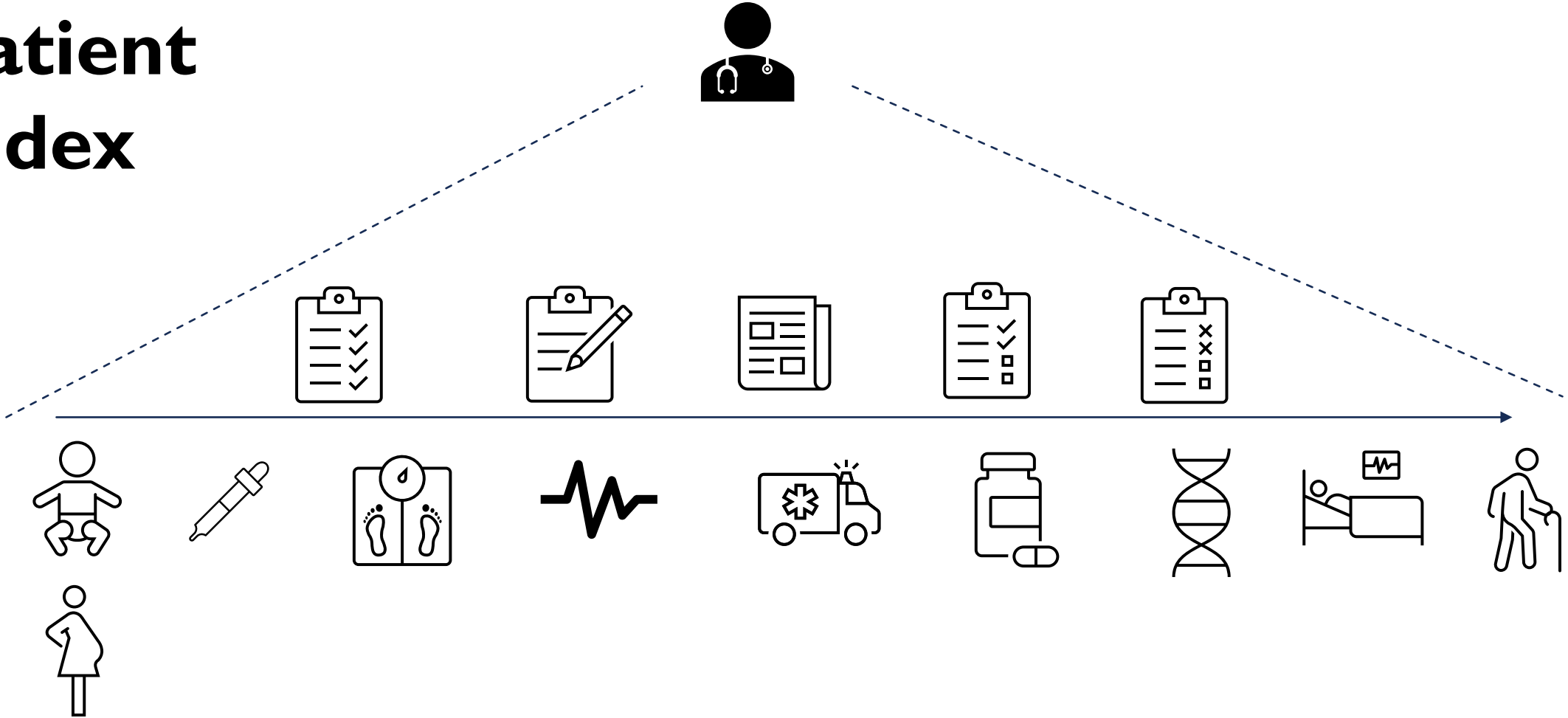

SYNTACTIC INTEROPERABILITY

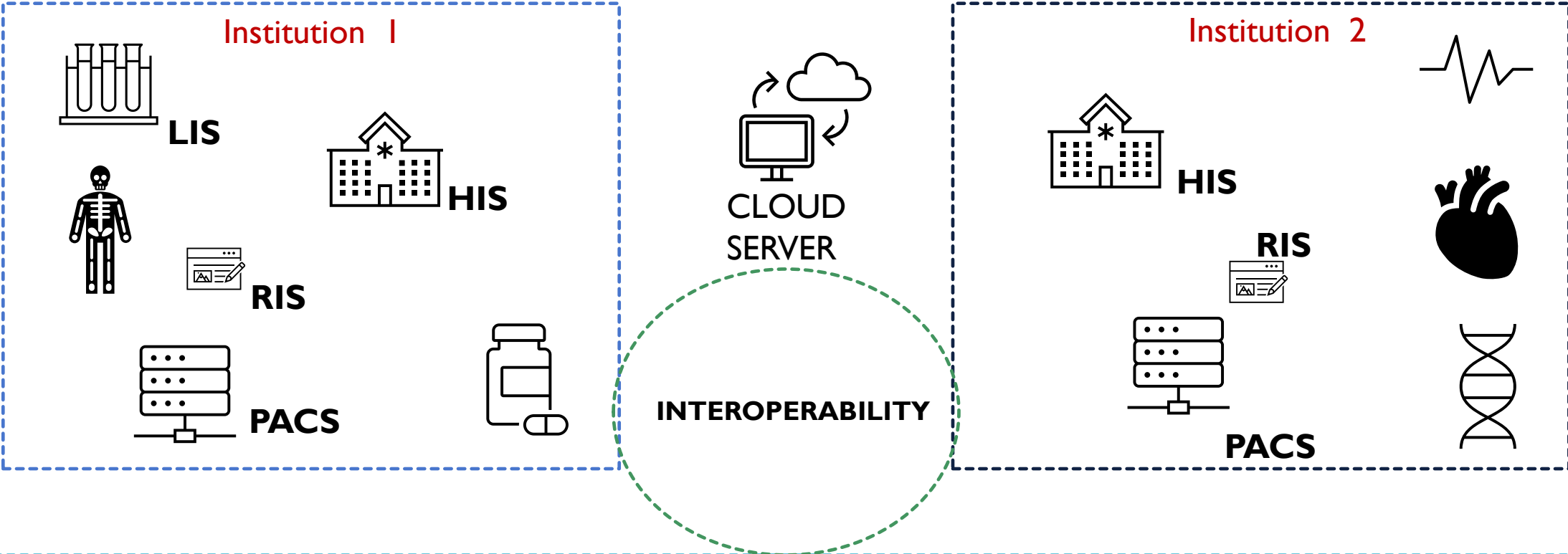

ORM / ORU HL7 V2.x Message

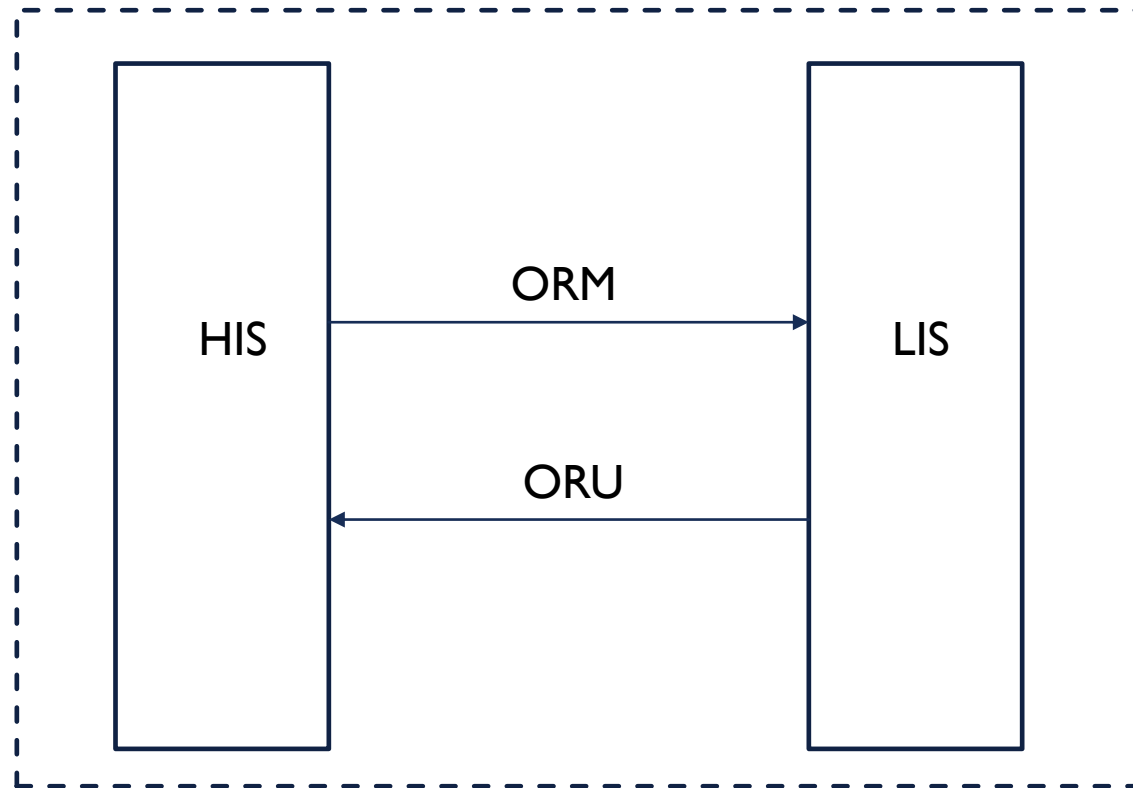

WHY AND EMPI

Implementing and EHR

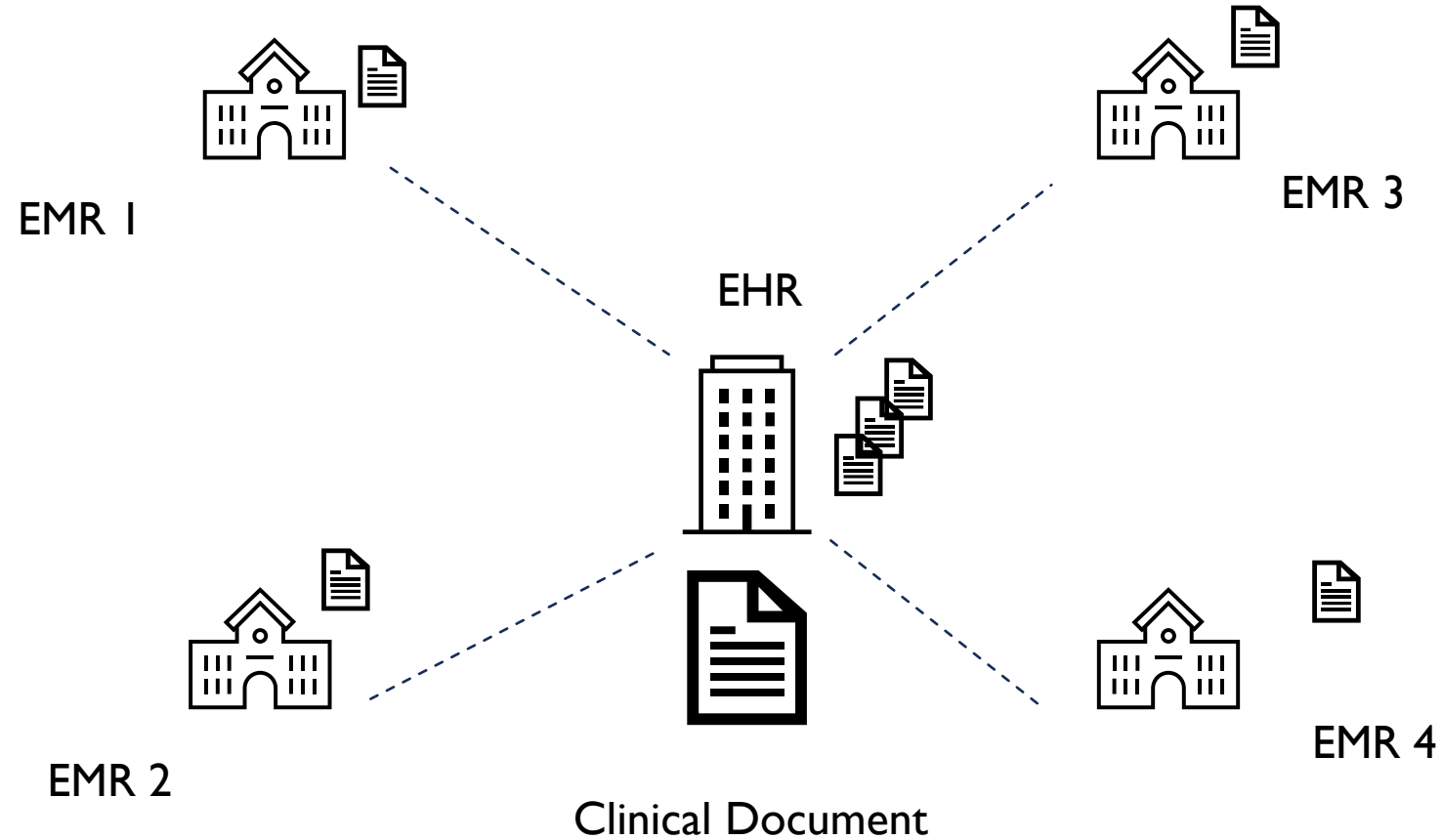

Enterprise Master Patient Index

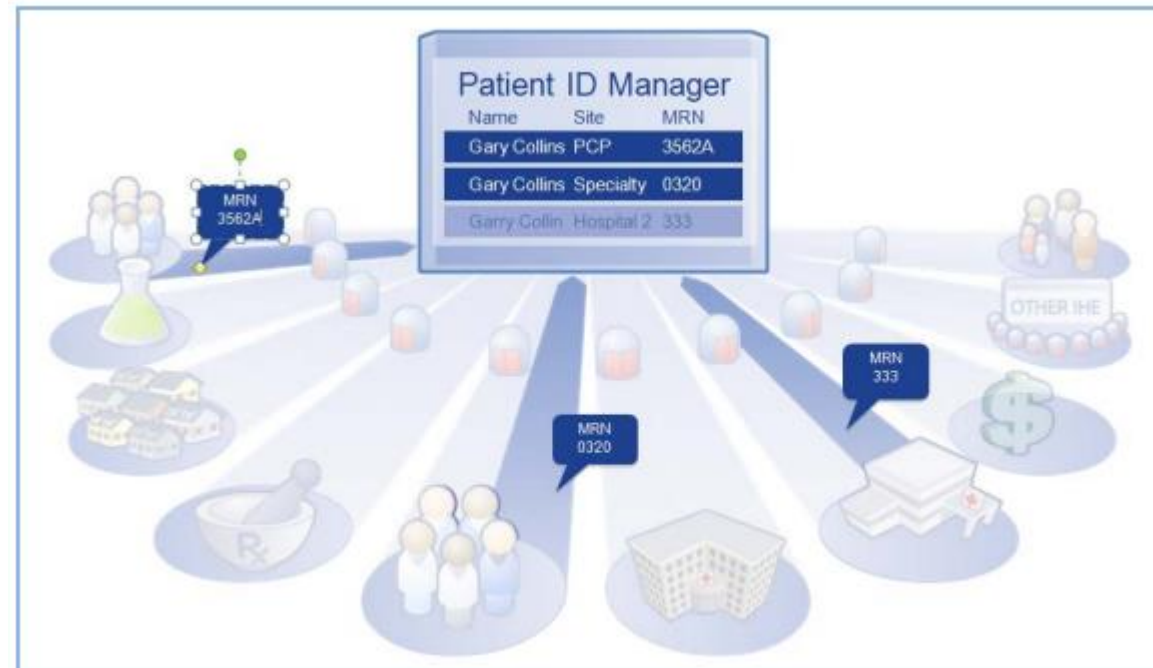

Patient identifier cross-referencing

Most health information systems assign each patient an identifier (usually a string of letters and/or numbers) that is unique to the patient within that information system. Thus, Gary Collins may be identified as 3562A at his primary care physician's (PCP) office and 0320A at his specialist's clinic.
in your specialist's clinic.

Different IDs in different health encounters

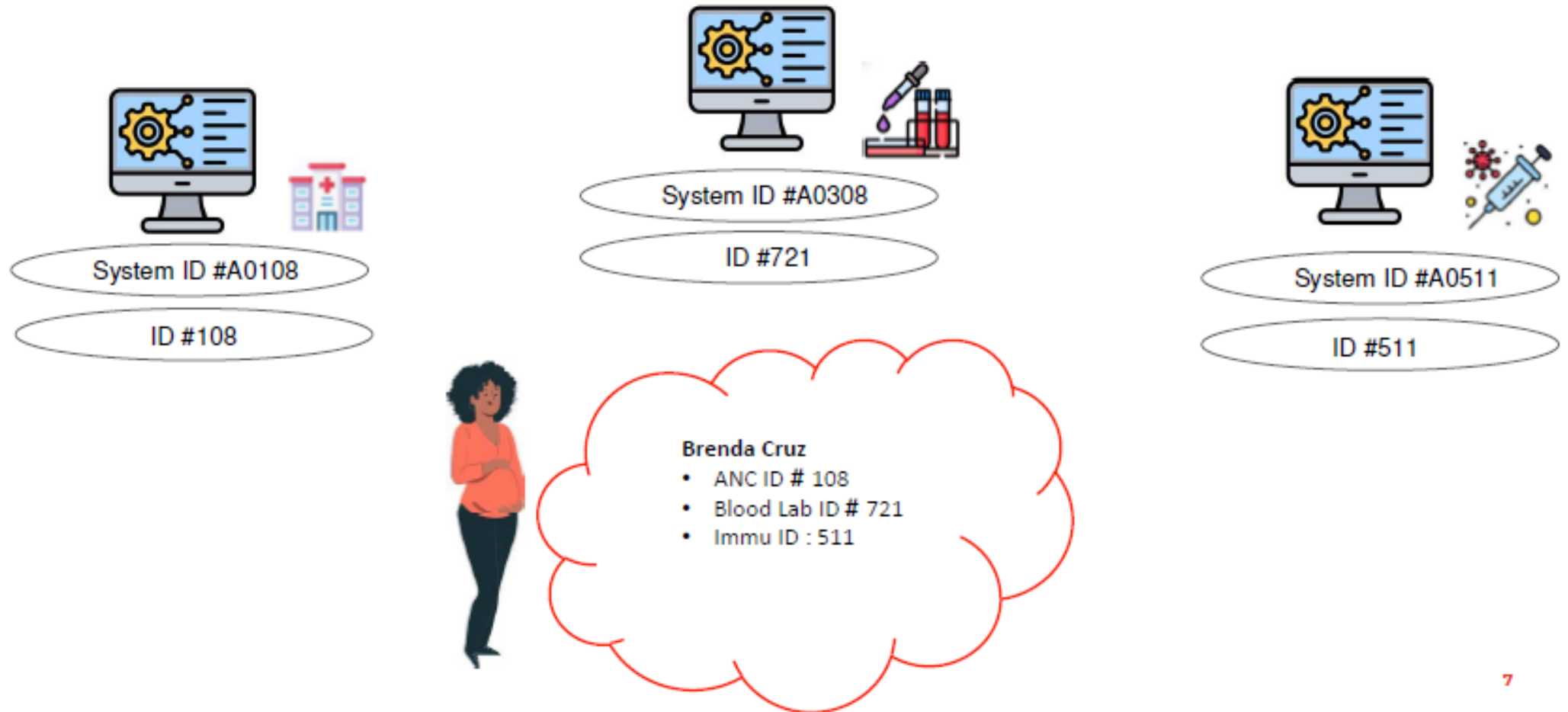

A

Update

**B**

More... ▾

**C**

More... ▾



More... ▾



| | | | | |
|---------------|--|--|--|-----------------------------|
| Summary | LAURA PAIRA TACUAVE MARTINEZ (33333) | LAURA PAIRA TACUABE MARTINEZ (44444) | LAURA PAIRA TACUABE MARTINEZ (55555) | RA TACUABE MARTINEZ (55555) |
| MPIID | 100000200 | 100000200 | 100000200 | |
| Work Category | | | | |
| Link Weight | | 41.935 | 37.786 | |
| Link Status | | Link | Link | |
| Link Reason | | Threshold | Threshold | |
| ID | 390 | 391 | 392 | |
| SSN | 22444424 | 22444424 | 22444427 | |
| Name.Given | LAURA | LAURA | LAURA | |
| Name.Middle | PAIRA | PAIRA | PAIRA | |
| Name.Family | TACUAVE MARTINEZ | TACUABE MARTINEZ | TACUABE MARTINEZ | MARTINEZ |
| Names | (empty) | (empty) | (empty) | |
| Gender | F | F | F | |
| BirthDateTime | 1980-05-25 | 1980-05-25 | 1980-06-25 | |
| Identifiers | (empty) | (empty) | (empty) | |
| Addresses | StreetLine PEDERNAL 2325 City MONTEVIDEO State MONTEVIDEO Use H | PEDERNAL 2325 MONTEVIDEO MONTEVIDEO H | PEDERNAL 2325 MONTEVIDEO MONTEVIDEO H | IAL 2325 IDEO IDEO |
| Telecoms | PhoneNumberFull 22011121 Use HP | 22011121 HP | 22011121 HP | |

IHE Integrating the Healthcare Enterprise



Domain

Profile

Profile

Actors

Transaction

Actor

Transaction

Public Health Laboratory Patology Cardiology
IT Infraestructure Pharmacy

XDS.b ATNA **PIX** **PDQ**
Feed Query



PIXm
PDQm
MHD

Document Source Document Consumer
Registry RepositoryITI-41 ITI-42 ITI-18

**PERFIL
PIX – PDQ**

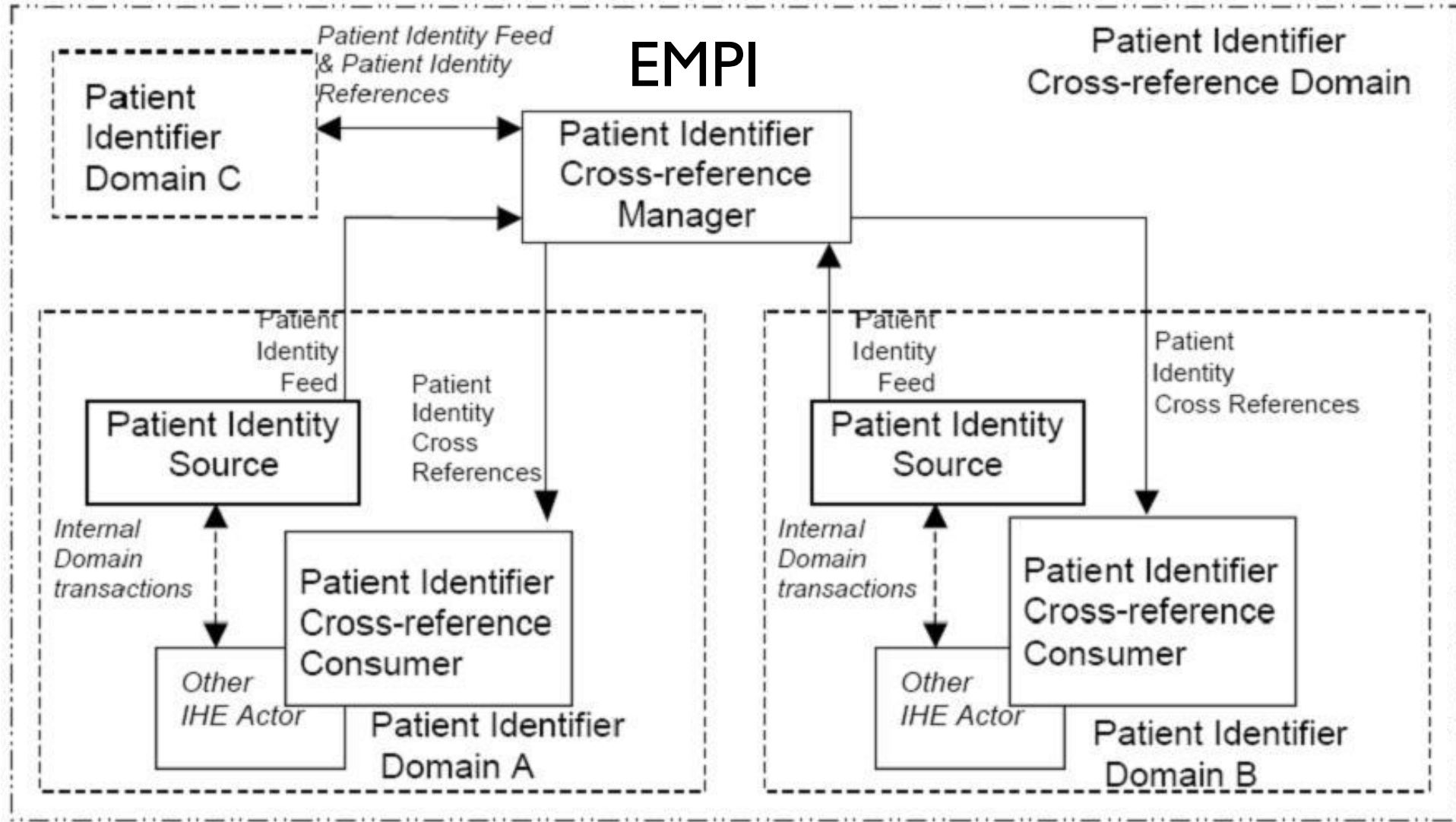

Who assign the identifier ?

Assigning authority

| Componente | DESCRIPCION | O/R |
|------------|------------------------|-----|
| HD.1 | Namespace | R |
| HD.2 | Universal ID | R |
| HD.3 | Universal ID Type (ID) | R |

HL7V2.X
Message



```
<PID.3>
  <CX.1>29223869<CX.1>
  <CX.4>
    <HD.1>AA_ASSE</HD.1>
    <HD.2>2.16.858.2.10001442.72768.1</HD.2>
    <HD.3>ISO</HD.3>
  </CX.4>
</PID.3>
<PID.3>
  <CX.1>60736049<CX.1>
  <CX.4>
    <HD.1>AA_DNIC</HD.1>
    <HD.2>2.16.858.2.1000675.68909</HD.2>
    <HD.3>ISO</HD.3>
  </CX.4>
</PID.3>
```

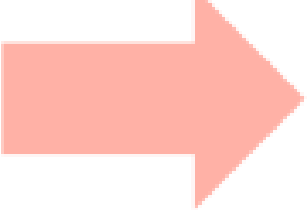

```
PUT http://example.org/fhir/Patient?identifier=urn:oid:1.3.6.1.4.1.21367.13.20.1000|IHERED-994 HTTP/1.1
Accept: application/fhir+json
Content-Type: application/fhir+json
```



```
{
  "resourceType": "Patient",
  "identifier": [
    {
      "system": "urn:oid:1.3.6.1.4.1.21367.13.20.1000",
      "value": "IHERED-994"
    }
  ],
  "active": true,
  "name": [
    {
      "family": "MOHR",
      "given": [
        "ALISSA"
      ]
    }
  ],
  "gender": "female",
  "birthDate": "1958-01-30"
}
```

IHE PROFILES - EHR

| Profile | Description | Propossal |
|----------------|--------------------------------------|--|
| PIX/PDQ | Patient Identifier Cross Referencing | Manage different identifiers for the patient |
| XDS.b | Cross-Enterprise Document Sharing | Share and query the Clinical Documents |
| XCA | Cross-Community Access | Integration of XDS.b infrastructures |
| ATNA | Audit Trail and Node Authentication | Auditory and autentication of transactions |

IHE - XDS.b - Transactions

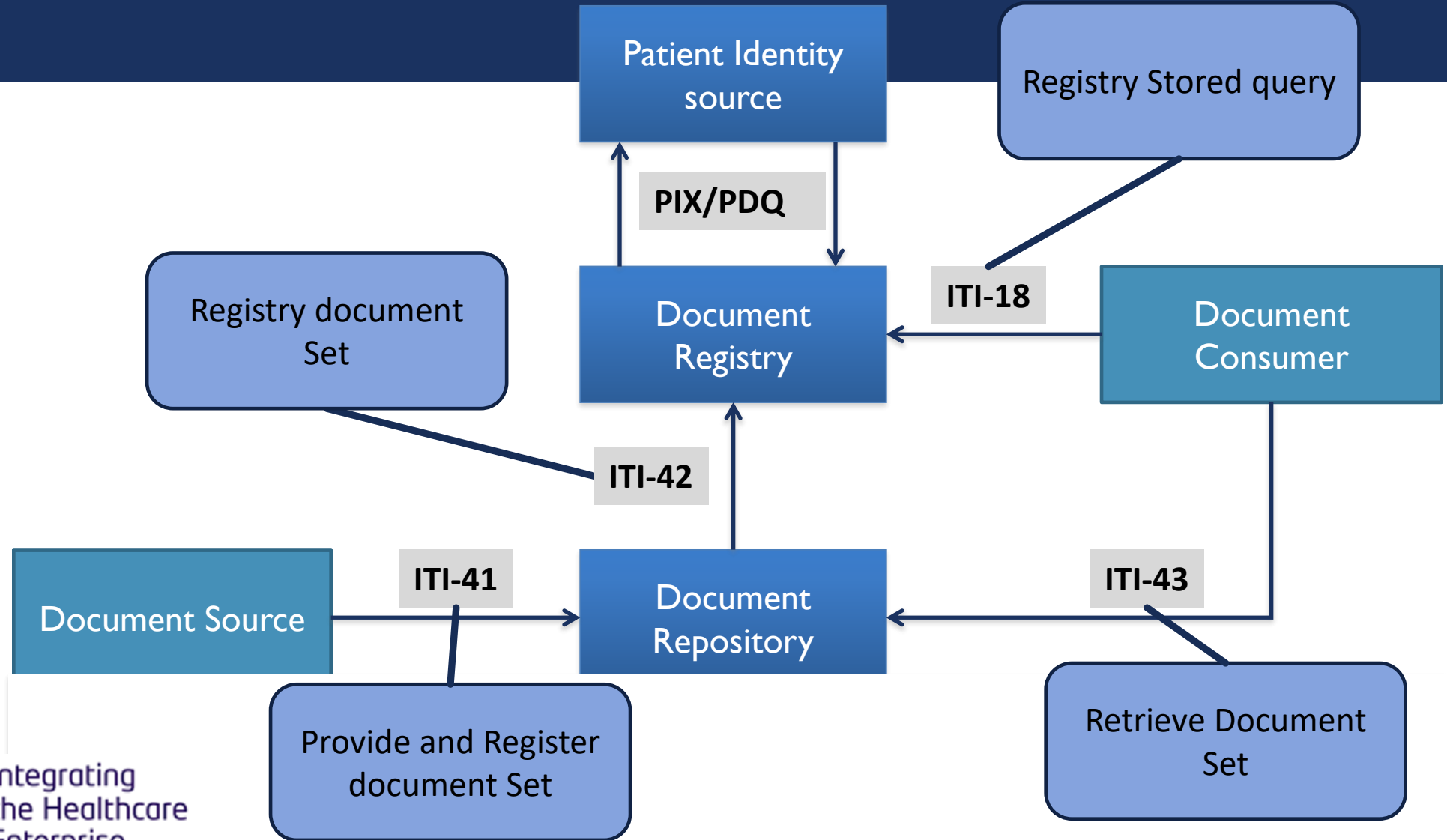



| | |
|----------------|-----------------------------|
| AA descripción | SALUDUY-TEST-UNO |
| AA OID | 2.16.858.2.10000005.72768.1 |

MPI Master Patient Index



| Dato persona | Valor |
|---------------------|---------------|
| MRN | 33333 |
| Documento | 22444424 |
| Primer nombre | Laura |
| Segundo nombre | Paira |
| Primer apellido | Tacuave |
| Segundo apellido | Martinez |
| Fecha de nacimiento | 25/05/1980 |
| Sexo | Femenino |
| Dirección | Pedernal 2325 |
| Teléfono | 22011121 |

XDS



| EMPIID | OID Documento | OID Repositorio |
|----------------------|---|--|
| 100000222 | 2.16.858.2.10000007.67430.20160815191543.1.1 | 2.16.858.2.10000007.71867.1 |
| 100000180 | 2.16.858.2.10000006.67430.20160705143045.1.1 | 2.16.858.2.10000006.71867.1 |
| 100000200 | 2.16.858.2.10000005.67430.20160928183450.1.1 | 2.16.858.2.10000005.71867.1 |
| 100000189 | 2.16.858.2.10000008.67430.20160120102012.1.1 | 2.16.858.2.10000008.71867.1 |
| 100000176 | 2.16.858.2.10000009.67430.20160407121032.1.1 | 2.16.858.2.10000009.71867.1 |

ELGA View on Data

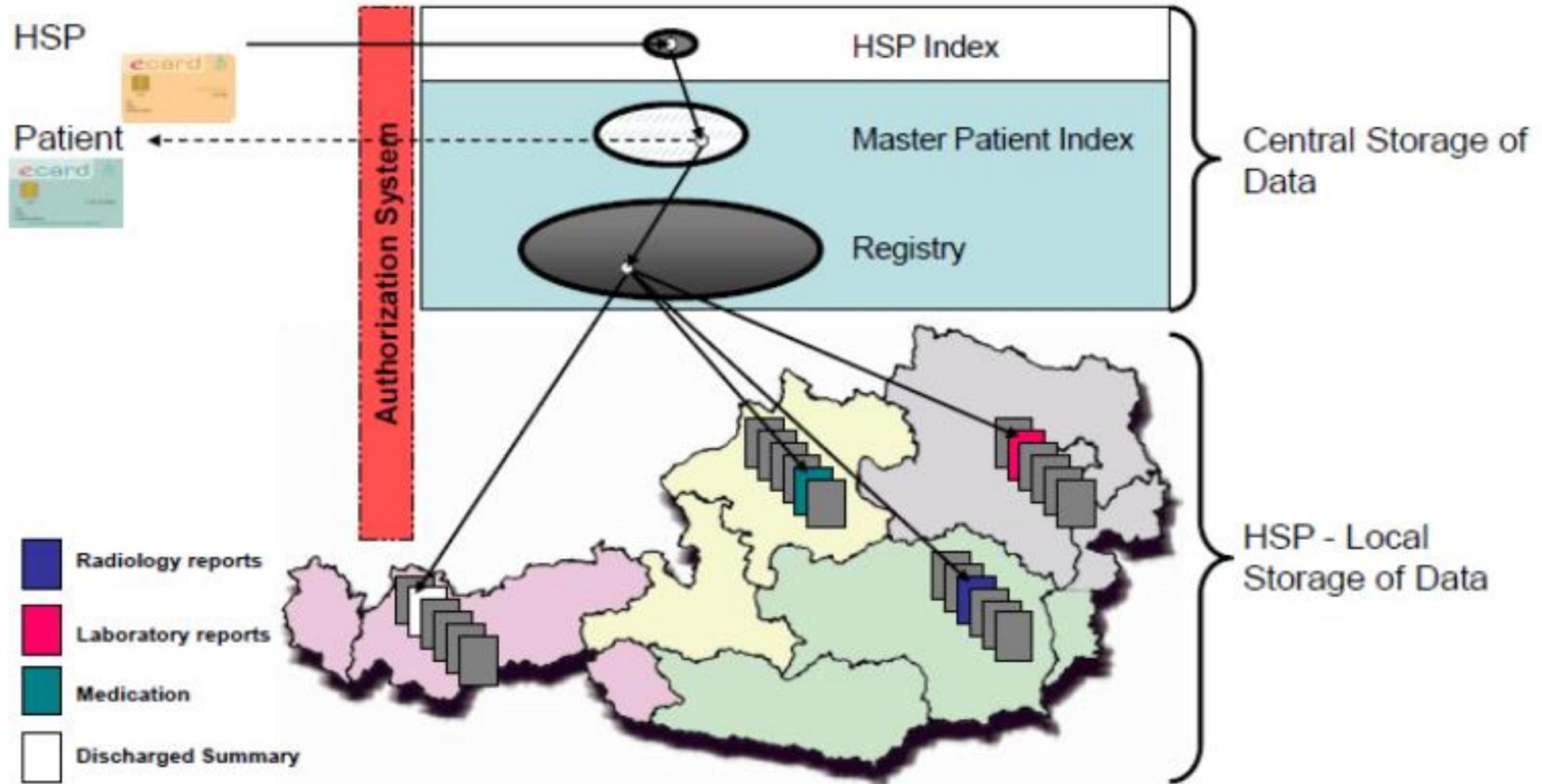

Technical framework for ELGA: IHE Profile XDS

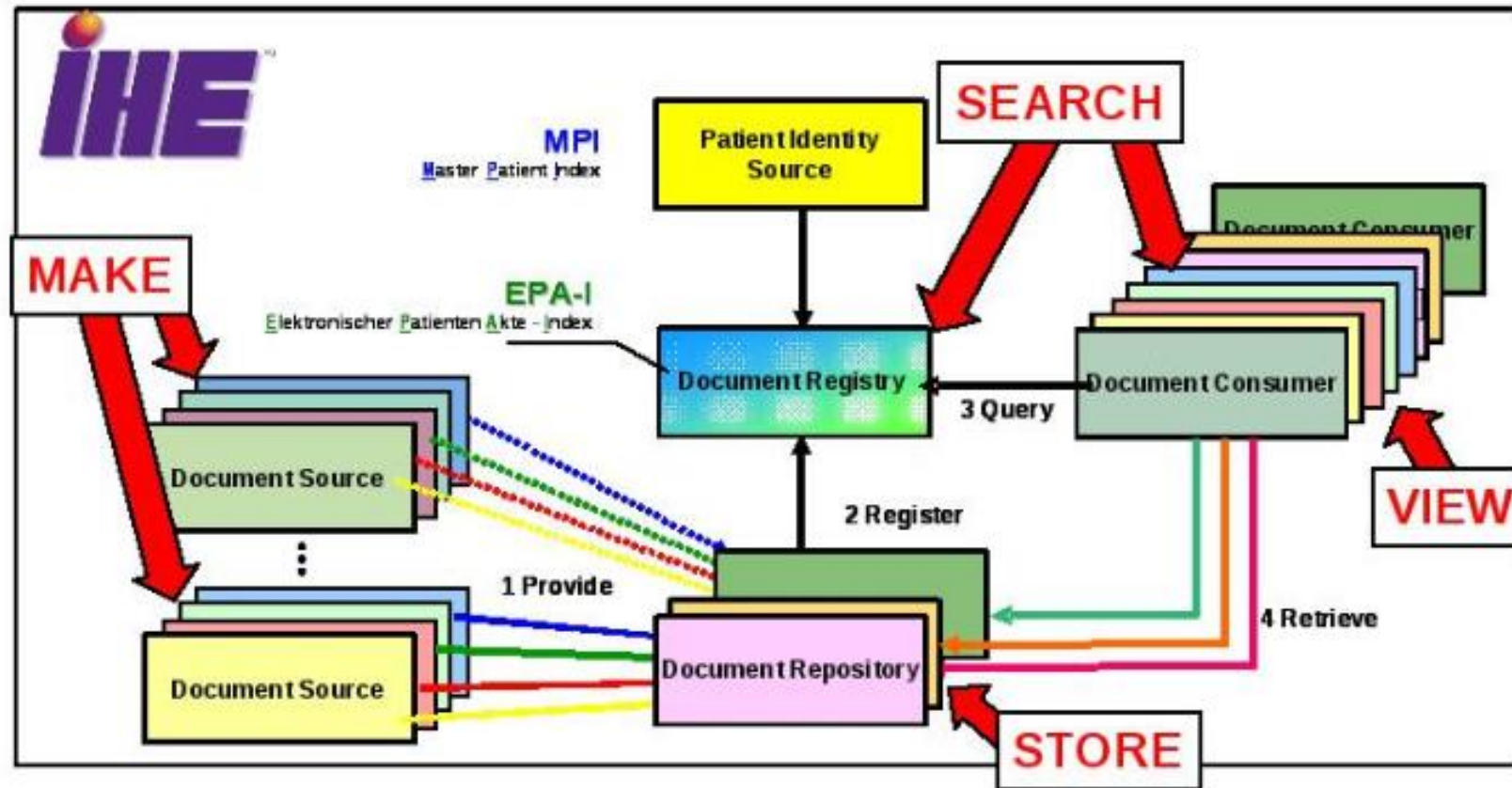



THANK YOU



MHSA, ING. PABLO OREFICE

[!\[\]\(74d4806277d7e73349d8e8c0897931e9_img.jpg\) /pabloorefice](https://www.linkedin.com/company/mhsa-ingenieria)



MDI, ING. FERNANDO PORTILLA

[!\[\]\(0b5e7e25e8775f7e7e80906ada4f0021_img.jpg\) /fernando-a-portilla-v-73b7b11a/](https://www.linkedin.com/company/fernan-do-a-portilla-v-73b7b11a/)